

FRONT ELEVATION

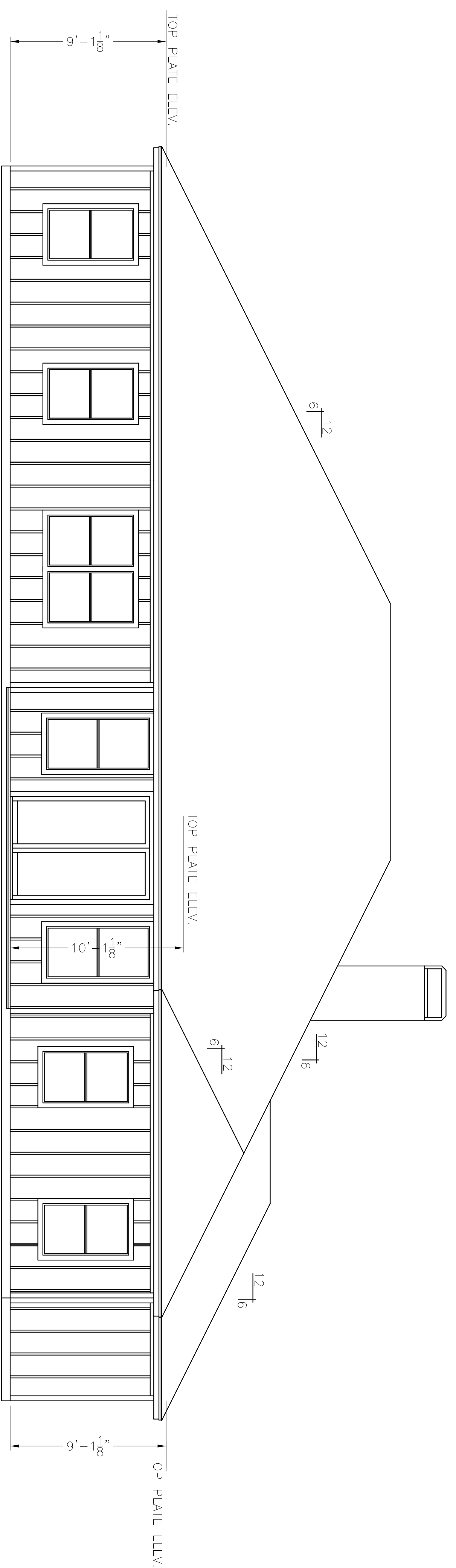

BACK ELEVATION

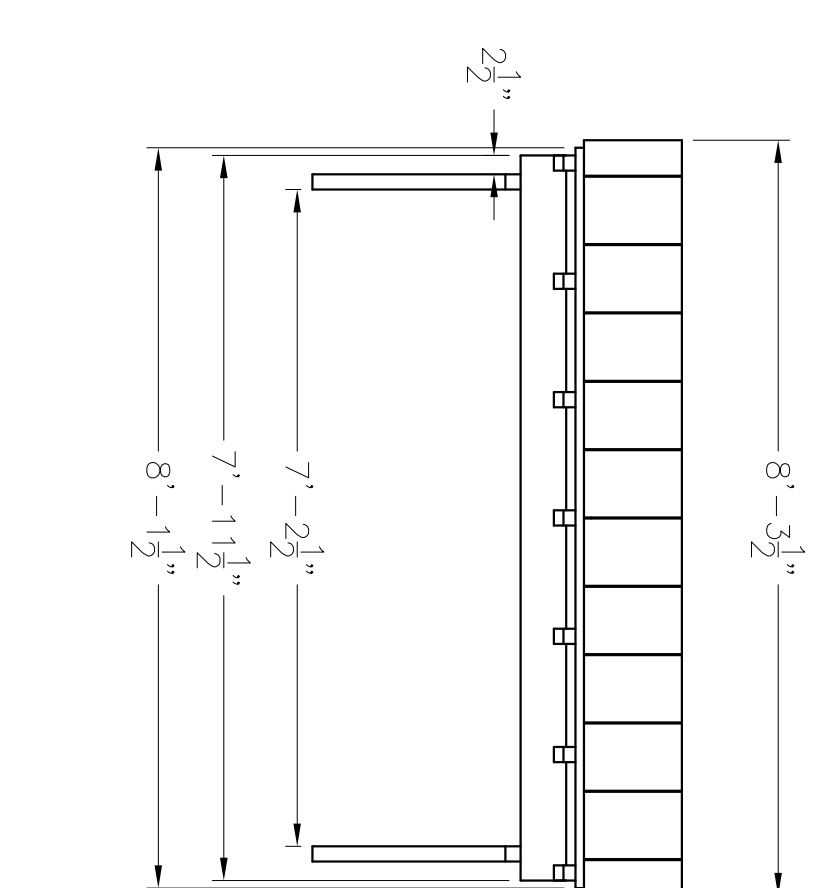

WINDOW CANOPY DETAILS

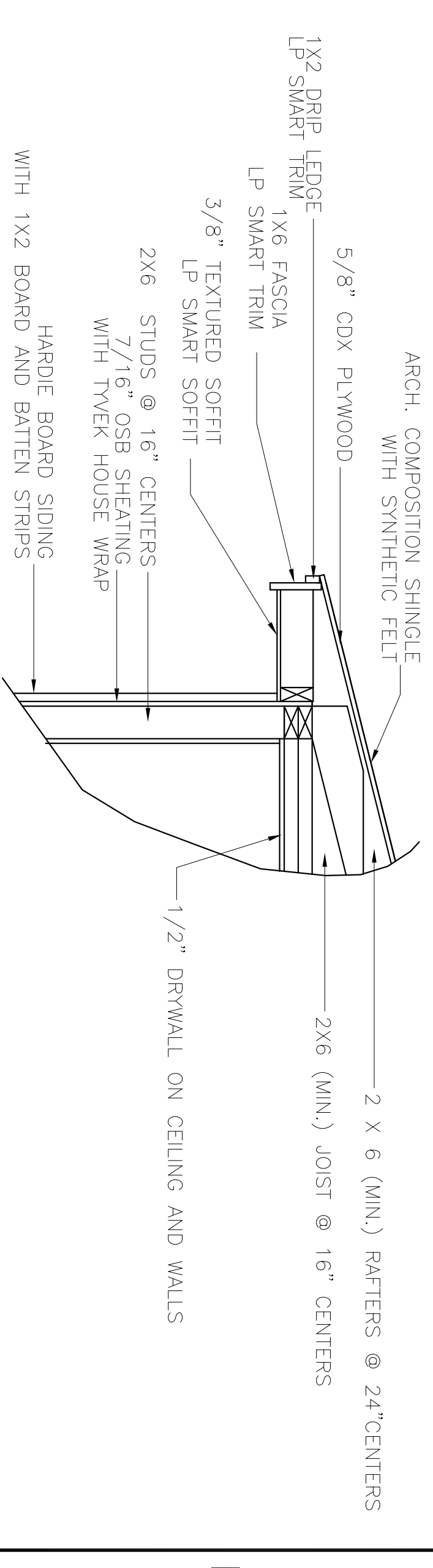
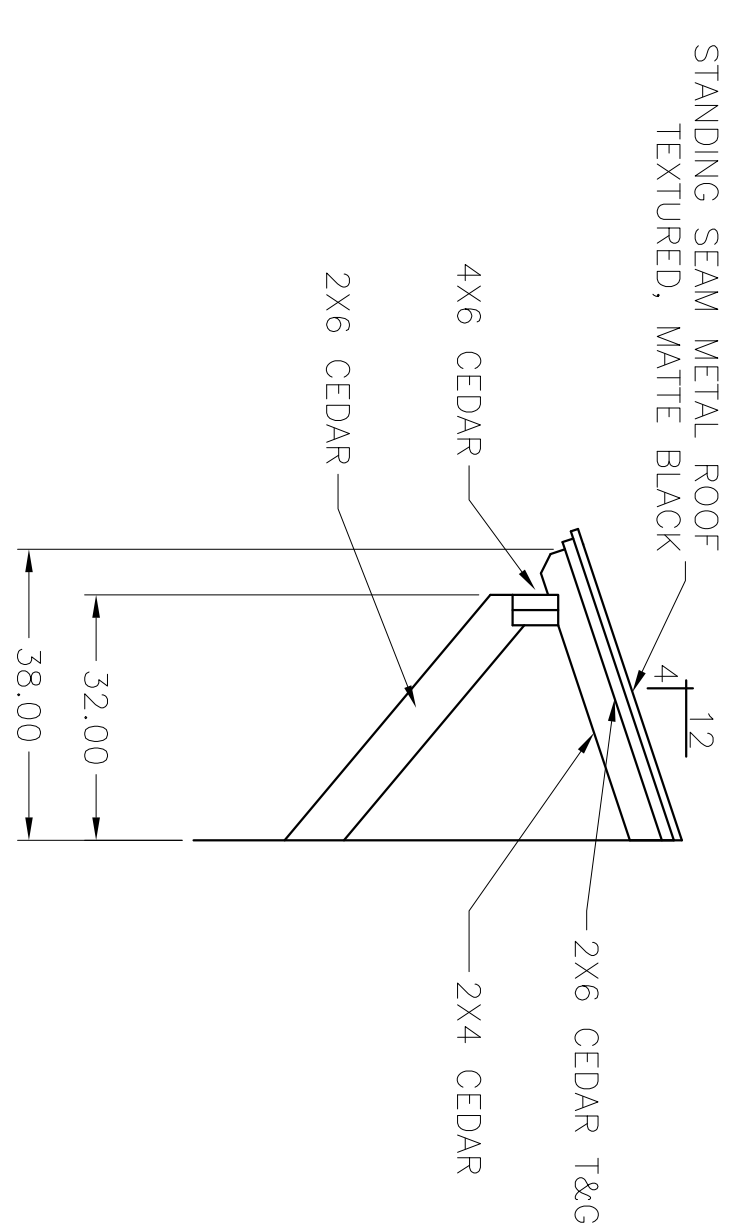

TYPICAL EXT. WALL SECTION

MAIN HOUSE: 3140 SQFT  
 PORCHES: 255 SQFT  
 GARAGE: 495 SQFT  
 TOTAL SLAB: 3890 SQFT

LEGAL

5401 COUNTY ROAD 206  
 GRANDVIEW, TEXAS 76050  
 11.5 ACRES, 500,940 SQUARE FEET  
 CHARLES R. SMITH AND  
 PATRICIA M. SMITH  
 VOLUME 2424, PAGE 399  
 D.R.J.C.T.  
 (CALLED 73.33 ACRES)

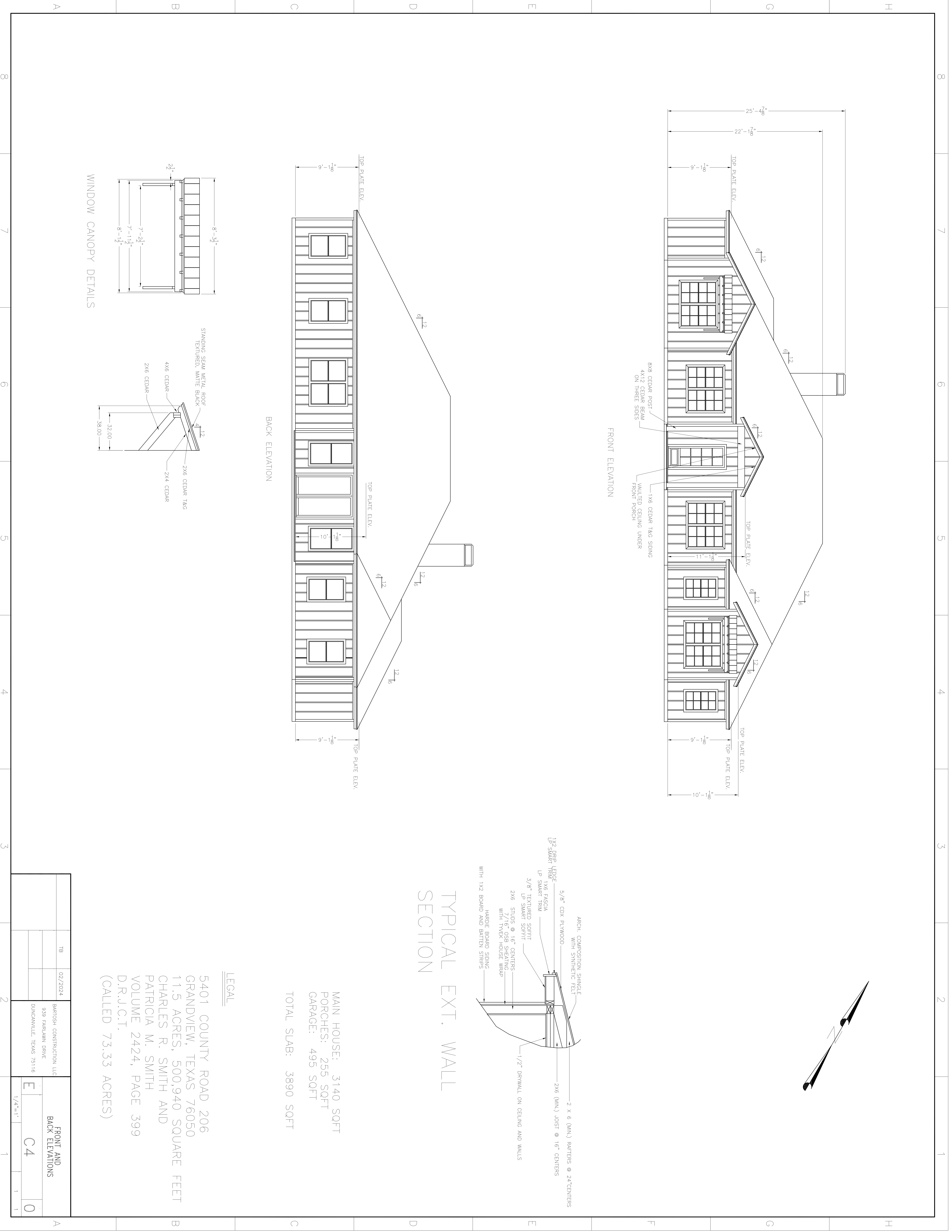
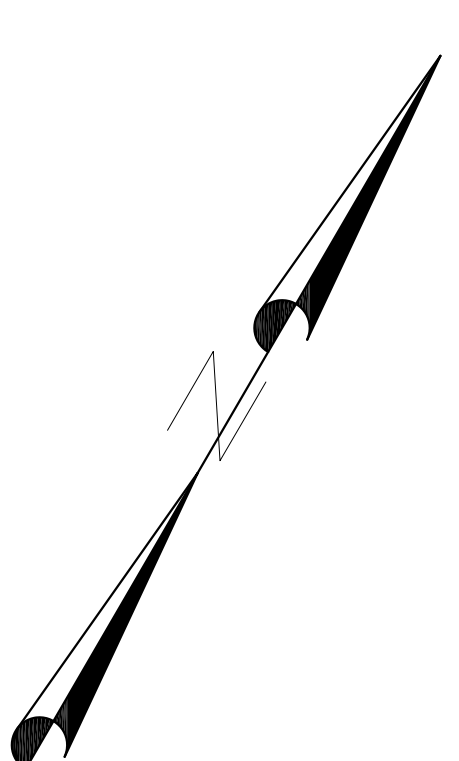

TB	02/2024	BARTOSH CONSTRUCTION LLC 939 FARLAWN DRIVE DUNCANVILLE, TEXAS 75116	FRONT AND BACK ELEVATIONS	C4	1	1	1
					1/4"=1'		